



**COFFRET 10" NOIR 9U Gamme Pro+**

Référence

**E806A2599**

**CARACTERISTIQUES TECHNIQUES**

**Coffret 10"**

<b>Unité</b>	<b>9U</b>
<b>Largeur</b>	<b>312 mm</b>
<b>Profondeur</b>	<b>300 mm</b>
<b>Dimensions (L x P x H)</b>	<b>312 x 300 x 483 mm</b>
<b>Capacité</b>	<b>30 kg</b>
<b>Couleur</b>	<b>Noir, RAL 9005 IP 20 en</b>
<b>Indice IP</b>	<b>standard</b>



**DESSIN TECHNIQUE**

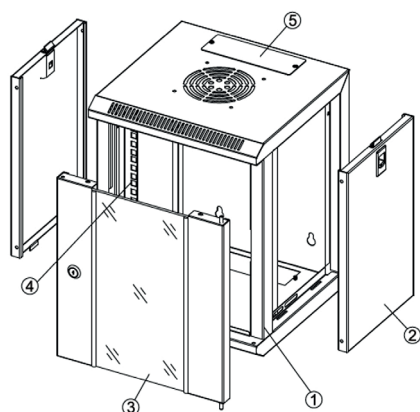

- ① Cadre (x1)
- ② Panneaux latéraux (x2)
- ③ Porte avant (x1)
- ④ Rails verticaux (x2)
- ⑤ Entrées des câbles (x2)

